

Polarization in Focus
Axio Scope and Axio Imager



**Innovative, Economical and Strain-free:
Polarization Microscopes for Education,
Routine and Research.**



We make it visible.

Innovation Sets New Standards

How to Get One Step Ahead in Polarization Microscopy

In the traditional fields of polarization microscopy – geology, mineralogy, metallurgy and the exploration of fossil fuel resources – microscopes have to meet higher standards than ever before.

Future-proof, upgradeable microscopes are an essential requirement in modern materialography as well as in the established areas of polarization microscopy. New challenges – in industries such as construction, glass, plastics, semiconductor, textile and fiber analysis as well as in forensic science – call for versatile, efficient and customized system solutions. Strain-free optics, highest optical resolution

and the availability of a wide range of contrasting and measurement techniques are a must, as is the choice of manual, motorized or encoded components. Equally important aspects are ease of use, value for money and digital analysis options, for both routine applications and research projects.



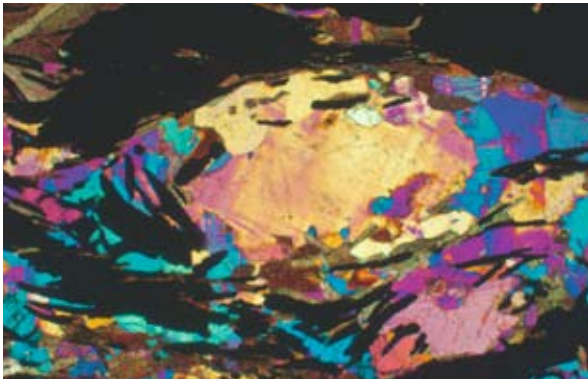

Carl Zeiss has always set the pace in polarization microscopy – with innovative, leading-edge systems that fulfill all your requirements: economical solutions for educational purposes, versatile microscopes for a wide variety of routine tasks and highly efficient instruments for each of your research endeavors. Two microscope stands form the basis for our system solutions: Axio Scope, a

multi-purpose routine stand, and Axio Imager, a powerful research instrument: both embody our promise of quality. As ever, Made by Carl Zeiss means that you can meet rising demands – in the lab, research institute, university or industry – even faster, more proficiently, reliably and economically.



Table of Contents

Contrasting Techniques – Diversity in Contrast	4
Quantitative Measurements – Precision is Our Trademark	7
Conoscopy – Designed for Conoscopy	8
Optics – Measuring Up to the Highest Standards	10
Axio Scope	12
Axio Imager	14
Axio Scope – Facts and Figures	16
Axio Imager – Facts and Figures	17
At a Glance – Tangible Benefits	18
Systems Overviews	19

Diversity in Contrast

What to Expect From Leading-Edge Polarization Microscopes

What to expect from Carl Zeiss polarization microscopes, no matter which contrast technique you use, is maximum performance and exceptional optical quality – time and again revealing just that little extra piece of information that can make all the difference to your results.



Dr Jutta Zipfel, Department of Meteorite Research,
Senckenberg Research Museum, Frankfurt/Main, Germany

In transmitted-light:

- Orthoscopy: linear and circular polarization
- Conoscopy
- Brightfield
- Darkfield
- Differential Interference Contrast (DIC)
- Phase Contrast
- PlasDIC

And in reflected-light:

- Brightfield
- Darkfield
- Polarization
- Fluorescence
- DIC and C-DIC

Contrasting: the possibilities are endless

Developed for traditional as well as current applications in polarization microscopy, Axio Scope and Axio Imager offer all relevant contrasting and measuring techniques.

Polarizers: Classic diversity

We offer a wide range of polarizers of various performance levels for both Axio Scope and Axio Imager. Each one provides a high level of polarization and color neutrality in the visible range of the spectrum, thereby ensuring exceptional images and precise measurements

Bar olivine chondrule in the Coolidge meteorite in transmitted-light

Objective: EC Plan-NEOFLUAR 10x/0.30 Pol

Dr Jutta Zipfel, Department of Meteorite Research, Senckenberg Research Museum, Frankfurt/Main, Germany

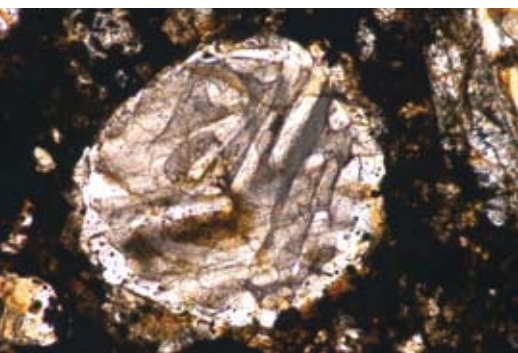

Brightfield

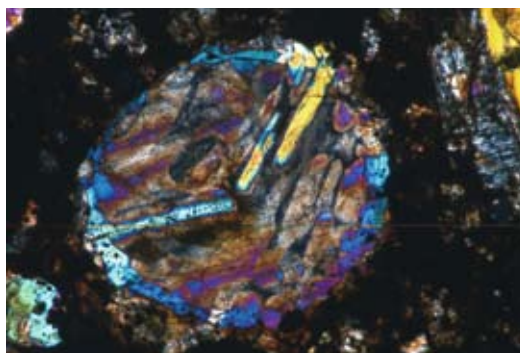

Polarization

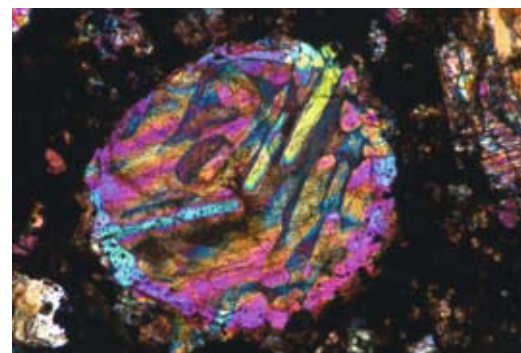

Polarization with λ -plate

State of polarization of the light			Rotation of the microscope stage				
			0°	45°	90°	135°	180°
Specimen	Zircon	linear					
		circular					
	Muscovite	linear					
		circular					

Behavior of optically anisotropic crystals in linearly and circularly polarized light, orthoscopy and conoscopy

according to industrial and other standards. The range comprises fixed and rotating polarizers for transmitted- and reflected-light. In addition, our portfolio includes 360° rotating quantitative analyzers with 0.1° vernier as well as combinations with a fixed or rotating lambda plate. We also offer a dedicated temperature-resistant polarizer module for the use in conjunction with the high energy arc lamp HBO103 in order to guarantee a consistent quality of polarization contrast.

Bar olivine chondrule in the Coolidge meteorite in reflected-light

Objective: EC Epiplan-NEOFLUAR 10x/0.25 Pol

Dr Jutta Zipfel, Department of Meteorite Research, Senckenberg Research Museum, Frankfurt/Main, Germany

Circular polarization: innovation in transmitted-light

Carl Zeiss polarization microscopes offer a further leading-edge innovation focused on your everyday requirements: the circular polarization device for transmitted-light. In contrast to the linear polarization currently predominantly in use, this device enables viewing and imaging devoid of any angular-dependent extinction; all features appear in their maximum interference colors. The benefits are obvious – for the photomicrography of thin rock sections as well as for structural examinations on plastics or strain distribution in glass using digital analysis systems.

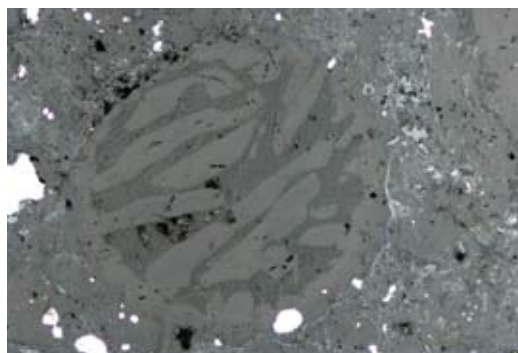

Brightfield

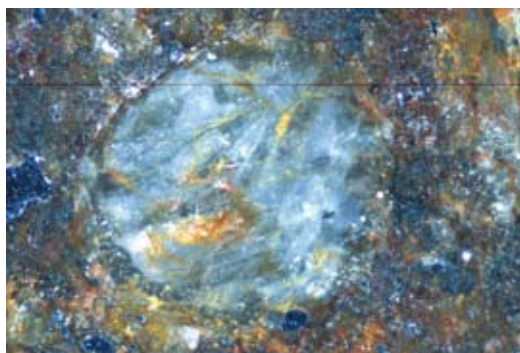

Darkfield

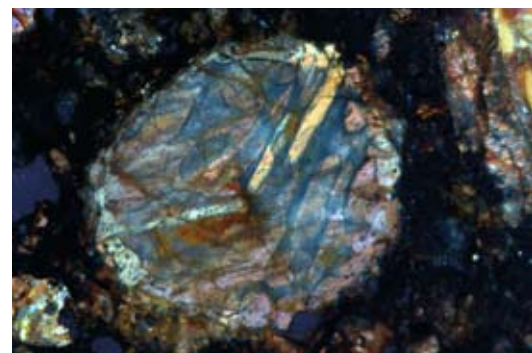

Polarization

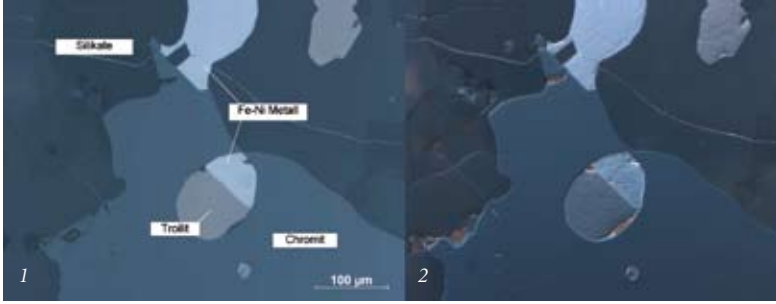

1 Brightfield, 2 C-DIC, mesosiderite in reflected-light
 Objective: EC Epiplan-NEOFLUAR 50x/0.8 Pol
 Dr Jutta Zipfel, Department of Meteorite Research,
 Senckenberg Research Museum, Frankfurt/Main, Germany

DIC or C-DIC: increased homogeneity, better contrast

The Differential Interference Contrast technique (DIC) has been further enhanced for objective magnifications from 5x to 100x, providing homogeneous illumination across the entire field of view. Circular DIC (C-DIC), an optical polarizing technique which, unlike standard DIC, uses circularly polarized light, is the perfect technique for studying oriented structures in reflected-light. Using C-DIC to contrast features with various spatial orientations has obvious advantages: Instead of having to rotate the sample in the azimuth, simply turning the DIC slider ring enables the user to view and image all features one after the other. By the way: The entire line of the general purpose objectives EC EPIPLAN requires only a single C-DIC prism for interference contrast in circularly polarized light.

Affordable excellence: PlasDIC

A DIC version generating polarization-optical Differential Interference Contrast in transmitted-light is available for the Axio Scope, providing excellent image quality even if the object, slide, condenser or objective lens displays anisotropic (birefringent) properties. PlasDIC is the technique of choice in the study of anisotropic samples if you would like to acquire an image with a three-dimensional, embossed character. The benefits are obvious: superior data and outstanding brilliance. In particular, compared to traditional brightfield, polarization or DIC methods, PlasDIC provides a significantly clearer distinction of specific features such as morphology or the crystal growth of anisotropic phases.

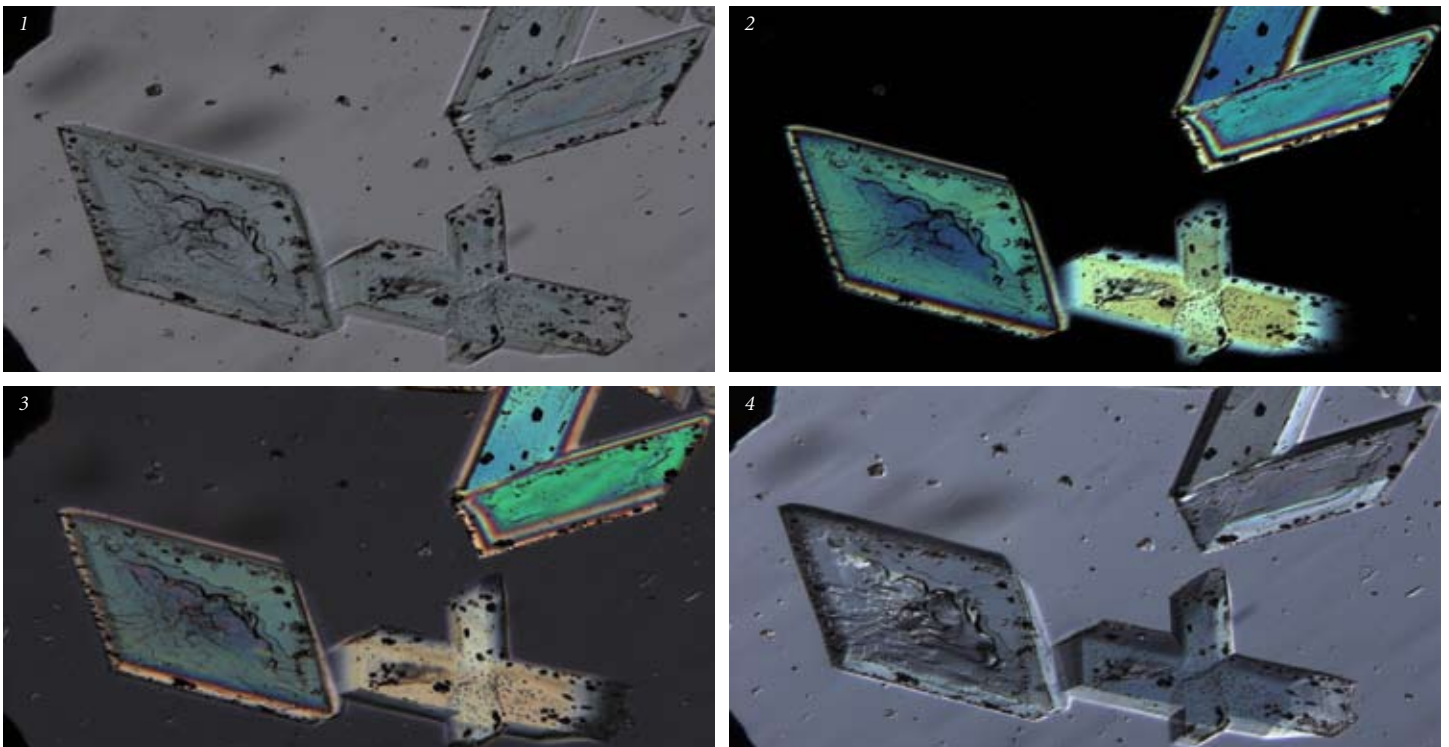

Copper sulfate crystals in transmitted-light: 1. Brightfield, 2 Polarization, 3 traditional DIC and 4 PlasDIC. PlasDIC allows this brilliant depiction of morphology for the first time.

Precision is Our Trademark

Quantitative Methods for Your Analysis

High performance in quantitative techniques – Carl Zeiss has a tailor-made solution for every polarization microscopy requirement

Diversity in quantitative measurements: manual and digital

Starting with the straightforward manual measurement by a rotating, ball bearing mounted stage with 360° division and 0.1° vernier – e.g. measuring cleavage angles in minerals – all the way to determining path differences or strain measurements: Carl Zeiss polarization microscopes

meet just about every challenge. A wide variety of compensators for the measuring range from 0 to 30 λ creates the basis. In addition, Axio Scope and Axio Imager offer an outstanding adaptability to a large number of other techniques. Examples include thermomicroscopy or image analysis functionalities such as grain size measurement or particle analysis with AxioVision software.



Compensators

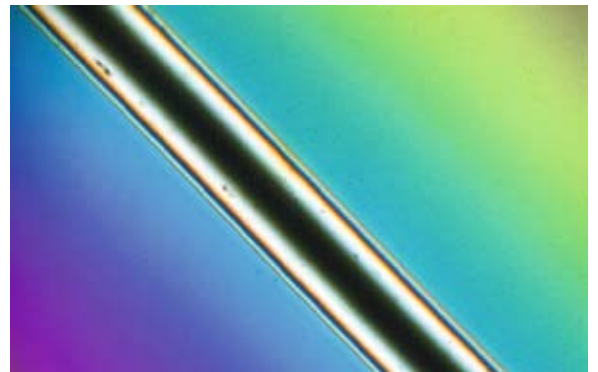

Nylon fiber, polarization, Berek compensator 0 to 5 λ

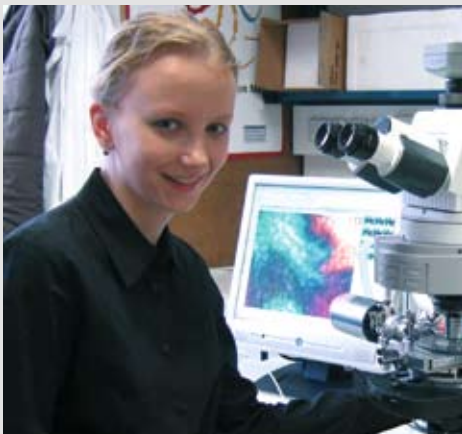

“In lyophilization microscopy we work with constant changes of magnification in order to monitor what happens to the materials in the heating chamber; which environmental conditions cause them to collapse. The motorization makes our job considerably easier. Axio Imager is extremely comfortable to work with. And we were simply thrilled with the image quality.”

*Dr Eva Meister
Research group Dr H. Gieseler
Division of Pharmaceutics, University of Erlangen-Nuremberg, Erlangen*

*Above right: Poly-L-Lysine in transmitted-light
Below right: Trypsinogen in transmitted-light
Objective: LD Epiplan 20x/0.25 DIC, Polarizer with rotary λ -plate*

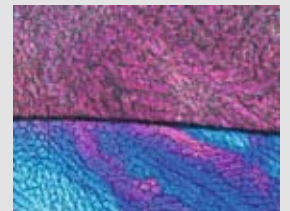

Designed for Conoscopy

Straightforward and Confident Mastery of a Demanding Technique

Carl Zeiss polarization microscopes provide the flexibility of fast, simple and economical system extensions for conoscopic measurements to suit each of your needs.

Economical or sophisticated: five choices for conoscopy

In many cases, the analysis of an interference image will provide even more valuable information for the classification of anisotropic material than the image of the object itself does. The polarization microscopes Axio Scope and Axio Imager from Carl Zeiss are available in a number of alternative configurations:

1. The pin-hole diaphragm or the auxiliary microscope in the eyepiece tube
The simplest and most economical version.
2. The conoscopy module
The module is simply inserted into the reflector turret or the reflector slider, is therefore easily exchanged

without the need for tools and allows the straightforward addition of the conoscopy function for crystal analysis to the polarization microscope at any time. Using the objective N-ACHROPLAN 50x/0.8 Pol or EC Plan-NEOFLUAR 40x/0.9 Pol, this makes performing conoscopy effortless and comfortable.

3. Conoscopy with the Bertrand lens slider
If the samples are uncovered or a 100x objective magnification is desired, conoscopy with the Bertrand lens slider is the solution of choice. The Bertrand lens can be focused, so that you can employ a wide range of objectives; for example EC Plan-NEOFLUAR 100x/1.30 Oil Pol or EC Epiplan-NEOFLUAR 50x/0.8 Pol.



With the conoscopy module, comprising Bertrand lens, analyzer and a high aperture objective (N-ACHROPLAN 50x/0.9 Pol or EC Plan-NEOFLUAR 40x/0.9 Pol) your microscope can be upgraded to conoscopy at any time.

Unaxial	State of polarization of the light			
	linear		circular	
	compensator λ			
	without	with	without	with
Positive quartz				
Negative calcite				

Determination of the optical characteristics of 1-axis and 2-axis minerals in linearly and circularly polarized light, the reference direction n_y of compensator λ is aligned in NO-SW.

In addition to the economical options detailed above, two more alternatives are available specifically for Axio Imager to allow the upgrade of your polarization microscope for conoscopy.

4. 5-position tube lens turret with integrated focusable Bertrand lens

Opting for a tube lens turret in order to acquire further magnifications will allow you to perform conoscopy in addition, as the tube lens turret contains an integrated Bertrand lens. The tube lens turret is available both in an encoded and in a motorized version.

5. Pol phototube

The Pol phototube has been specifically designed for orthoscopy and conoscopy with Axio Imager. There is a significant advantage to this choice: Due to an additional intermediate image plane, object, cross hairs and iris diaphragm can be viewed concurrently. Thanks to the adjustable iris diaphragm this is also true for the limits of conoscopic range, down to a minimum crystal size of 10 μm . The Bertrand optics are pre-centered and focusable and are straightforward to turn on and off with the help of a slider. As a result, the correlation of orthoscopic and conoscopic image data can be easily verified at any time. An ideal solution for fast, reliable crystal analysis.

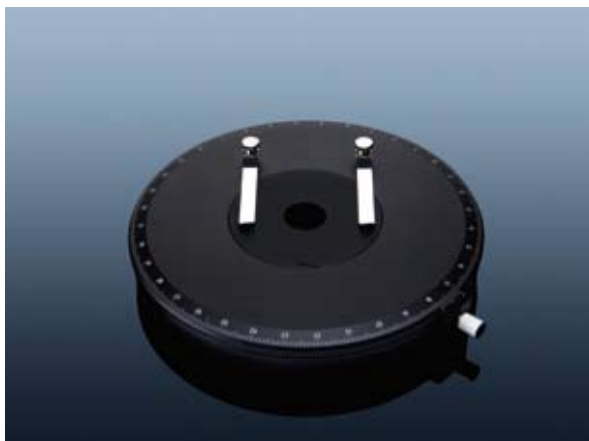

Small rotary stage with stage clips: 360° division with 0.1° vernier

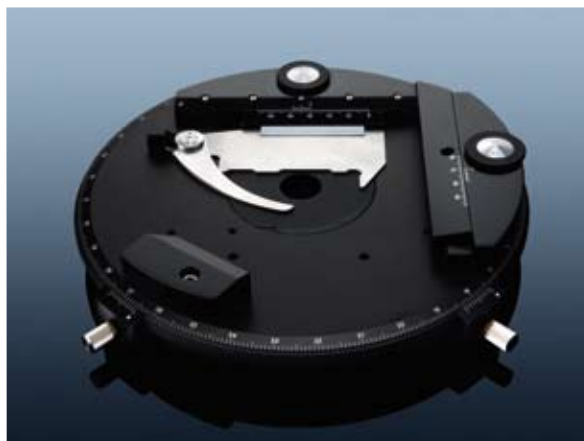

Pol rotary stage with adjustable 45° click stops and stage clips. Vernier 0.1°, object guide for transmitted- and reflected-light applications (with and without click stops)

Measuring Up to the Highest Standards

Carl Zeiss Redefines the Limits of Optics

Optics of uncompromising quality form the basis for setting new standards in polarization microscopy. The keyword here is strain-free. This principle is embodied by the availability of a wide range of polarization objectives in various performance classes and price levels – tailor-made for your requirements.

The six-position centering nosepiece: added convenience for polarization

The six-position Pol* centering nosepiece offers much space for your objectives, eliminating the need for time-consuming objective or turret changes; clearly a plus for enhanced efficiency. The rotary stage is centered in relation to the fixed turret opening which serves as the reference. Subsequently, the remaining openings are centered in the turret individually – the image position therefore remains unaffected by each change of magnification. Being equipped with M27 threads, the turret accommodates the whole range of standard contrast

*Axio Imager: encoded; Axio Scope: manual

techniques in transmitted- and reflected-light, as well as reflected-light applications in darkfield. Additionally, the turret features a position to house a DIC-slider for Differential Interference Contrast.

Polarization strain-free: the objectives

Four ranges of objectives share one ambition: Only those merit the label Pol which qualify for work in polarized light due to exceptionally low strain. Carl Zeiss offers four lines of strain-free objectives, varying in the extent of correction, price level and application area.

Pol – Polarization, DIC – Differential Interference Contrast

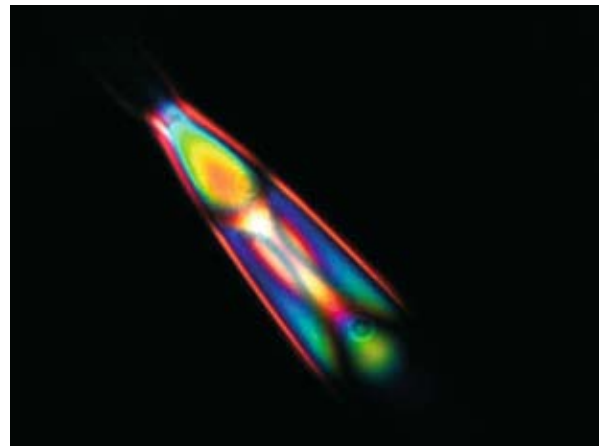

*Glass fiber filled with liquid crystal, linearly polarized transmitted-light
Objective: EC Epiplan-NEOFLUAR 50x/0.80 Pol
Thomas Tanggaard Larsen, COM Research Center, Technical
University of Denmark, Lyngby, Denmark; and Peter Hansen,
Crystal Fibre A/S, Birkerød, Denmark*

	Objective lens	Suitable up to field of view	Flatness of field	Color correction
	<p>N-ACHROPLAN Pol The transmitted-light lenses for samples with cover glass. With further enhancement of color correction and flattening, this is the attractively-priced, entry-level line for polarizing microscopy – ideal for education and routine.</p>	23	Very good	Very good
	<p>EC Plan-NEOFLUAR Pol The Enhanced Contrast transmitted-light objective lenses for samples with a cover glass. With their consistent minimization of stray light and contrast enhancement, these lenses meet demanding requirements. The EC Plan-NEOFLUAR lenses feature full chromatic correction for the focal plane. With their high resolving power, they offer a crisp, high-contrast and completely flat image for observation and documentation.</p>	25	Excellent	Excellent
	<p>EC EPIPLAN Pol Transmitted- and reflected-light objective lenses for uncovered samples in routine applications. The Enhanced Contrast series is achromatically corrected and generates a flattened field for an intermediate image size of 23 mm. The objective lenses feature blocked pupil positions and therefore allow the C-DIC contrasting technique.</p>	23	Very good	Very good
	<p>EC Epiplan-NEOFLUAR Pol The transmitted- and reflected-light objective lenses for advanced applications for samples with or without a cover glass. Optimized for maximum contrast, their outstanding features include increased numerical apertures and therefore a higher resolving power. These lenses are suitable for transmitted-light examinations. However, due to the spherical aberration, objects with a cover glass can only be examined up to a magnification of 20x. There are no restrictions for samples without a cover glass. Rigorous, object-side telecentricity makes these lenses particularly suitable for measuring purposes.</p>	25	Excellent	Excellent
	<p>In addition, the Epiplan-NEOFLUAR Pol line offers you a selection of immersion lenses.</p>			

You can get further information at www.zeiss.de/objectives.

Axio Scope

Why Twenty-Nine Stand Versions Offer a Perfect Solution for Every Application and Budget

Exceptional diversity – of stand versions and interfaces – creates exceptional flexibility and the foundation for a tailor-made configuration for your application, encompassing functionality and economic efficiency.

A new dimension in modularity

Axio Scope is customized specifically for your applications; a microscope dedicated to your individual polarization microscopy needs. Two different polarization microscopy units are available for combination with a choice of three different bases. Your microscope configuration is tailor-made, however straightforward or complex your requirements may be; for transmitted-light, reflected-light or both. For example, as a combined transmitted-light and reflected-light stand for geoscience training courses or as a reflected-light only stand in the exploration industry (e.g. coal mining). A significant advantage for your budget: you only invest in the components you actually need.

Economical upgrading

Future upgrades to Axio Scope are both straightforward and cost-effective, thanks to the modular interface design: an attractive economical aspect, especially as many add-ons can be easily installed by the user.

Polarization microscopy units:

- I. For transmitted-light applications in polarized light
Instrument requirements: 6-position centering nose-piece Pol, including 5x H Pol, 1x H DIC; compensator mount above centering turret (for λ -plates, quartz

wedge or quantitative compensators etc.)

- II. For transmitted- and reflected-light applications in polarized light
Instrument requirements: 6-position centering nose-piece Pol, including 5x HD Pol, 1x HD DIC. 100 W halogen lamp; beam path with Koehler illumination; slots for rotary reflected-light polarizer, luminous field diaphragm, filter slider and swing-out diffusor.

Bases

- A. Straightforward base section, no beam path, suitable for reflected-light microscopy; can be adapted to transmitted-light with an LED (Fixed-Koehler) fixed underneath the condenser carrier
- B. For all standard transmitted-light applications
50 W reflector lamp, beam path with Koehler illumination; luminous field diaphragm, filter slider and 6-position filter wheel
- C. For advanced transmitted-light applications with high illumination intensity
Beam path with Koehler illumination, luminous field diaphragm and aperture diaphragm, filter slider and 6-position filter wheel

H – Brightfield, D – Darkfield, Pol – Polarization, DIC – Differential Interference Contrast



The variety of interfaces is a special performance feature of Axio Scope. It varies depending on which upper and lower bodies are used. In the example: upper body II and lower body B.

- 1 Tube for either
 - Intermediate plate
 - Tube lens turret or for
- 2 Upper body
- 3 Reflector space
 - 2-position slider
 - 4-position turret
 - 6-position turret
- 4 Upper body for either
 - 30 or 60 mm spacer or for
- 5 Lower body
- 6 Stage carrier
- 7 Stage
- 8 Condenser carrier
- 9 Condenser
- 10 Transmitted-light filter wheel
- 11 Compartment for 6x20 mm slider, Compensators, C-DIC slider
- 12 Compartment for DIC slider
- 13 Objective lenses
- 14 Rotary polarizer
- 15 Luminous field diaphragm
- 16 Aperture diaphragm
- 17 Reflected-light filter slider
- 18 Achromatic illumination adapter and interface for illumination HAL 100/HBO, etc.
- 19 Transmitted-light filter slider
- 20 Transmitted-light polarizer
- 21 Transmitted-/reflected-light analyzer



From 0 to 110 mm: variable sample space

There are a number of options available for extending the sample space vertically in order to accommodate taller samples. In addition to z-travel this can be achieved by

- Lowering the stage carrier with the dovetail
- Removing the condenser carrier, for example if the stage is intended to be lowered beyond the travel range
- Inserting a 30 mm or 60 mm spacer, utilizing the customer interface between the polarization microscopy units (I, II) and the bases (A, B, C). The 30 mm and 60 mm spacer extend the maximum sample height to 80 mm and 110 mm respectively

The flexible sample space provides additional freedom of use and extends the range of applications for Axio Scope.

Interface for reflector modules: infinity space

The interface in the infinity space is unique in this category. Axio Scope allows you to use those reflector modules that are best suited for your applications. You have the choice of a 2-position slider, a 4-position reflector turret or a 6-position turret. No matter which alternative you prefer, all of them are easily fitted with Push&Click modules. With each option, your optics modules are held safely and dust-free.



Axio Imager

Comfort and Convenience - Provided by an Intelligent Polarization Microscope

The intelligent microscope assists in controlling your workflows, making them easier and even more reliable – with Axio Imager, Carl Zeiss has implemented a concept with regards to stand diversity, ease of use and ergonomics that will amaze you.

The stand versions: 9 times more flexible

More economic efficiency in polarization microscopy – Axio Imager gives you the freedom to tailor your research microscope to your requirements. Nine stands are available. You can opt for the encoded, partly motorized or fully motorized version, as all key components of Axio Imager are encoded.

The imaging cell

Stability is a major prerequisite for best results. The core elements of Axio Imager – objective turret, z-guide and stage carrier – are constructed as a compact, vibration-free unit. This stable cell is decoupled from the remaining stand, creating ideal conditions for imaging, particularly for time-lapse experiments using high magnifications.

The touchscreen: innovation at a glance

Complex workflows made easy – the most relevant functionalities of the motorized polarization microscope are available on a touchscreen (TFT). The control of all motorized components is at your fingertips. In addition to the factory settings, complex processes can be programmed, saved and retrieved at the touch of a button on the screen.

Light manager and contrast manager: the automatic way to optimum settings

The light manager is designed to provide reproducible illumination settings and stable imaging conditions leading to optimum illumination and contrast. This is achieved by automatically regulating the lamp voltage, ensuring



The touchscreen on the stand (left) or the docking station (right) provide clear guidance in control and configuration.

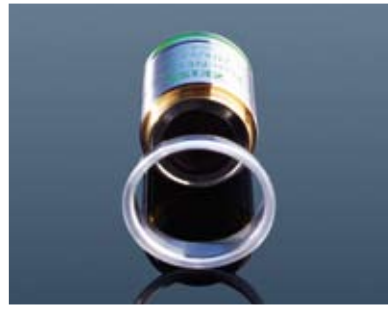

Automatic Component Recognition recognizes objective lenses and reflector modules automatically

*left: ACR reflector module
right: ACR objective lens*

constant color temperature via neutral density filters and controlling the motorized luminous field diaphragm and aperture diaphragm, both in the reflected- and transmitted-light beam paths. That way, settings – e.g. diaphragm settings relating to specific objectives – can be saved to be retrieved at any time. The contrast manager on the other hand will direct you quickly and reliably to the correct setting for a given contrast technique. Simply select the desired technique on the TFT and the contrast manager will handle the complex interactions of parameters such as the position of shutter, reflector turret and/or modulator turret.

Control buttons: functionality you can feel

Another smart detail in the design of Axio Imager: tactile control buttons. Ergonomically arranged around the focus drive, they are easily distinguished by their position and shape.

Operating panel: microscopy without the microscope

Designed to provide more freedom of moving around in the lab – Axio Imager can be controlled via an operating panel, which can be positioned separately from the microscope stand. The panel features a focus drive and brightness control. Other functions can be programmed by the user. The panel offers an interface for the TFT and for the x-, y-control of the motorized stage. A well-conceived design for more convenience.

Automatic component recognition: hallmark of the research microscope

The innovative ACR – Automatic Component Recognition – system automatically identifies objectives and reflector modules in all motorized Axio Imager versions. Any exchange of components is immediately registered in the system. Confidence in the correct settings provides peace of mind. Automatically.



Two different kinds of fine focus controls are available for the focusing drive in Axio Imager: They are interchangeable and can be used either on the left or the right hand side.

Axio Scope.A1 for polarizing microscopy – facts and figures

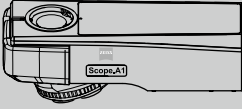
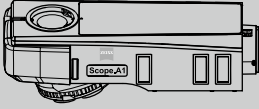
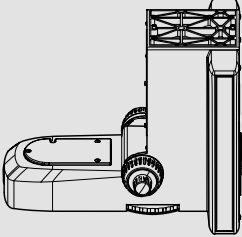
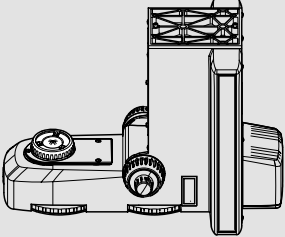
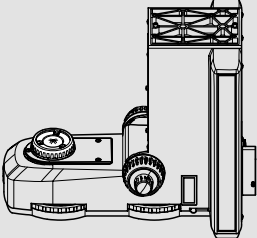
<p>Upper body of stand</p> <p>Lower body of stand</p>	<p>Upper body for transmitted-light</p> <p>with objective turret 5x H Pol / 1x H DIC, M27</p> 	<p>Upper body for reflected- and transmitted-light</p> <p>with objective turret 5x HD Pol / 1x HD DIC, M27</p> 
<p>Lower body of stand for LED illumination</p> 	<p>Microscope stand Axio Scope.A1 LED 5x H Pol / 1x H DIC</p> <p>430035-9240-000</p>	<p>Microscope stand Axio Scope.A1 LED, HAL 100 5x HD Pol / 1x HD DIC</p> <p>430035-9270-000</p>
<p>Lower body of stand for HAL 50 illumination</p> 	<p>Microscope stand Axio Scope.A1 HAL 50, 5x H Pol / 1x H DIC</p> <p>430035-9250-000</p>	<p>Microscope stand Axio Scope.A1 HAL 50, HAL 100, 5x HD Pol / 1x HD DIC</p> <p>430035-9280-000</p>
<p>Lower body of stand for HAL 100 illumination</p> 	<p>Microscope stand Axio Scope.A1 HAL 100, HAL 100 5x H Pol / 1x H DIC</p> <p>430035-9260-000</p>	<p>Microscope stand Axio Scope.A1 HAL 100, HAL 100, 5x HD Pol / 1x HD DIC</p> <p>430035-9290-000</p>

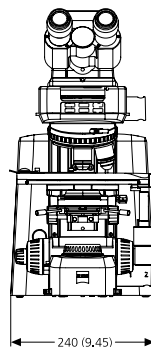
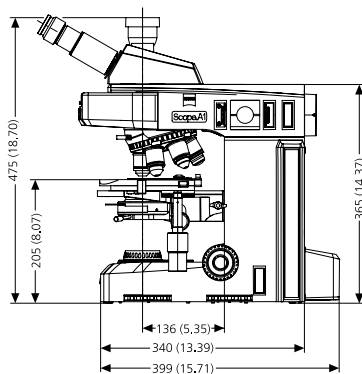

Dimensions in mm (inches)

Axio Imager 2 for polarizing microscopy – facts and figures

Axio Imager – flexibility for all fields of application										
Components	Option	A2 LED	A2	M2	D2	Z2	A2m	M2m	D2m	Z2m
Stand	manual	+	+	-	+	-	+	-	+	-
	motorized	-	-	+	O*	+	-	+	O*	+
Encoding	readable from computer	+	+	+	+	+	+	+	+	+
Tube lens turret	encoded	O	O	O	O	O	O	O	O	O
	motorized	-	-	O	-	O	-	O	-	O
Reflector turret	6x encoded	O	O	O	O	O	O	-	O	O
	6x motorized	-	-	O	O	O	-	+	O	O
	6x motorized ACR	-	-	-	-	O	-	-	-	O
	10x motorized ACR**	-	-	-	-	O	-	-	O	O
Objektiv turret	6x encoded POL	O	O	O	O	O	O	O	O	O
	6x encoded HD DIC	O	O	O	O	O	O	O	O	O
	6x motorized HD DIC	-	-	O	-	O	-	O	-	O
	6x motorized HD DIC ACR	-	-	O	-	O	-	O	-	O
	7x encoded HD	O	O	O	O	O	O	O	O	O
Modulator turret for C-DIC/TIC	7x motorized HD	-	-	O	-	O	-	O	-	O
	manual	O	O	O	O	O	O	O	O	O
Modulator turret for transmitted-light DIC	motorized*****	-	-	O	-	O	-	O	-	O
	motorized*****	-	-	-	-	O	-	-	-	O
Stage carrier, attachable with condenser carrier	0 mm - 25 mm	+	+	+	+	O	O	O	O	O
Stage carrier, attachable, for removable condenser carrier	0 mm - 45 mm	O	O	O	O	O	O	O	O	O
Stage carrier, reflected-light	0 mm - 63 mm	O	O	O	O	O	O	O	O	O
Transmitted-light illumination	manual	-	+	-	+	-	O	O	O	O
	motorized	-	-	+	-	+	-	-	-	O
LED transmitted-light	-	+	O	O	O	O	O	O	O	O
Double wheel filter transmitted-light	manual	-	+	O	O	O	O	O	O	O
	motorized	-	-	O	-	O	-	-	-	O
Reflected-light illumination	manual***	O	O	O	O	O	+	-	+	-
	motorized***	-	-	-	-	O	-	+	-	+
Luminous field diaphragm, reflected-light	manual	O	O	O	O	O	+	O	+	O
	motorized	-	-	-	-	O	-	O	-	O
Aperture diaphragm, reflected-light	manual	O	O	O	O	O	O	O	O	O
	motorized	-	-	-	-	O	-	O	-	O
Double wheel filter, reflected-light	manual	O	O	O	O	O	O	O	O	O
	motorized	-	-	O	-	O	-	O	-	O
FL attenuator	manual	O	O	O	O	O	O	O	O	O
	motorized	-	-	-	-	O	-	O	-	O
Light switchover reflected-/transmitted-light	manual	+	+	-	+	-	+	-	+	-
	software	-	-	+	-	+	-	+	-	+
Mixed light with additional power unit	manual	+	+	-	+	-	+	-	+	-
	software	-	-	+	-	+	-	+	-	+
Focus (z-axis)	manual	+	+	-	+	-	+	-	+	-
	motorized 25 nm	-	-	+	-	-	-	+	-	-
	High performance focus (motorized 10 nm)	-	-	-	-	+	-	-	-	+
TFT display	-	-	+	-	+	-	-	+	-	+
ApoTome	-	O	O	O	O	O	O	O	O	O
Power unit	external	-	-	+	-	+	-	+	-	+
	internal	+	+	-	+	-	+	-	+	-
Mechanical stages CAN	motorized****	O	O	O	O	O	O	O	O	O
Scanning stages	piezo	O	O	O	O	O	O	O	O	O
	DC/stepper motors	O	O	O	O	O	O	O	O	O
Fast z-piezo insert	with manual stage	O	O	O	O	O	O	O	O	O
	with scanning stage	O	O	O	O	O	O	O	O	O
2 TV tube, motorized	-	-	-	O	-	O	-	O	-	O
Condensers	manual	O	O	O	O	O	O	O	O	O
	motorized	-	-	O	-	O	-	O	-	O

- + = Contained in the stand
- O = Optionally available
- = Not possible
- * = Motorized (6x and 10x) reflector turret can be used
- ** = ACR function not possible with Axio Imager.D2 and D2m
- *** = All reflected-light illumination devices contain a motorized shutter.
For fluorescence applications this can be optionally replaced with a high-speed shutter
- **** = For use on Axio Imager.A2 LED, A2, A2m, D2 and D2m, USB/CAN converter 432909 is required
- ***** = Only in combination with objective turret mot.
- m = Optimized for materials applications

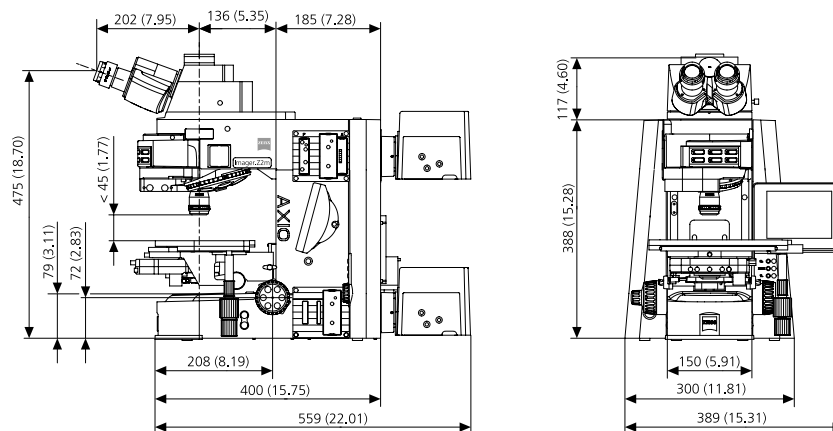

Dimensions in mm (inches)

Concrete benefits

What details you should know for polarizing microscopy

	Axio Scope.A1	Axio Imager 2
Stands	6 manual stand models optionally available as transmitted-light, reflected-light or transmitted-/reflected-light stands	9 encoded, partly motorized or fully motorized stand versions optionally available as transmitted-light, reflected-light or transmitted-/reflected-light stands
Field of view number	23	23/25
Illumination	Reflected-light: 100 W HAL, HBO Transmitted-light: 100 W HAL, 50 W HAL or LED	Reflected-light: 100 W HAL, HBO Transmitted-light: 100 W HAL, LED
Optics	Proven ICS optics, optionally with achromatic correction lens system	Innovative IC ² S infinity system for considerably more contrast in all established contrasting techniques
	High quality and economical entry-level line of polarizing objective lenses for transmitted-light: N-ACHROPLAN Pol	
	Enhanced Contrast, the new generations of high contrast polarizing objective lenses: Transmitted-light: EC Plan-NEOFLUAR Pol, reflected-light: EC EPIPLAN Pol, EC Epiplan-NEOFLUAR Pol, oil immersion objective lenses	
Contrasting methods	Transmitted-light: qualitative and quantitative polarizing techniques, orthoscopy, linear and circular polarization, conoscopy, brightfield, dark-field, Phase Contrast, Differential Interference Contrast, PlasDIC*	
	Reflected-light: qualitative and quantitative polarization, brightfield, darkfield, Differential Interference Contrast (DIC), Differential Interference Contrast in circularly polarized light (C-DIC), fluorescence	
Contrast change	Manual contrast change via Reflector slider 2x Reflector turret 4x Reflector turret 6x	Contrast change via encoded or motorized Reflector turret Reflector turret 6x encoded Reflector turret 6x mot. Reflector turret 6x mot. ACR Reflector turret 10x ACR
Change of modules Push&Click without tool		
Objective turret	6x centering objective turret Pol, thread M27	6x centering objective turret Pol, thread M27 encoded
Polarizers	Transmitted-light: Polarizer (switchable), polarizer (rotary with 0° and 90° click stops), polarizer (switchable with lambda plate, rotary), circular polarizer	
	Reflected-light: Reflector module Pol, Reflector module Pol for HBO103, Polarizer rotary 0-90°	Reflector module Pol, Reflector module Pol for HBO103, Measuring polarizer, rotatable 360° with 0.1° vernier
Analyzers	Analyzer module or analyzer slider or slider with analyzer and lambda plate, rotatable 360° or measuring analyzer with 0.1° division, rotatable 360°	
Conoscopy	Bertrand lens module (fixed focus) Bertrand lens slider (focusable)	
		Tube lens turret with focusable Bertrand lens Pol phototube with focusable Bertrand lens Crosshairs and visual field diaphragm in additional intermediate image plane
Ergonomy/ease of use	Convenient intensity setting Ergo tube/ergo phototube: 20° viewing angle, vertical adjustment in range of 50 mm	Ergo phototubes Contrast manager Light manager Touchscreen Remote control
Software	AxioVision microscope software Basic version, upgradeable with functional modules such as MosaiX, Panorama, particle analysis or grain size analysis	
Cameras	Open interface for each camera type (video and digital consumer cameras, scientific microscope cameras) In particular AxioCam ICc 1 and AxioCam ICc 3, AxioCam HRC, AxioCam MRc or AxioCam MRC 5	

ICS – Infinity Color Corrected System

IC²S – Infinity Contrast and Color Corrected System

ACR – Automated Component Recognition

* possible in Axio Scope only

Axio Scope.A1 for polarization

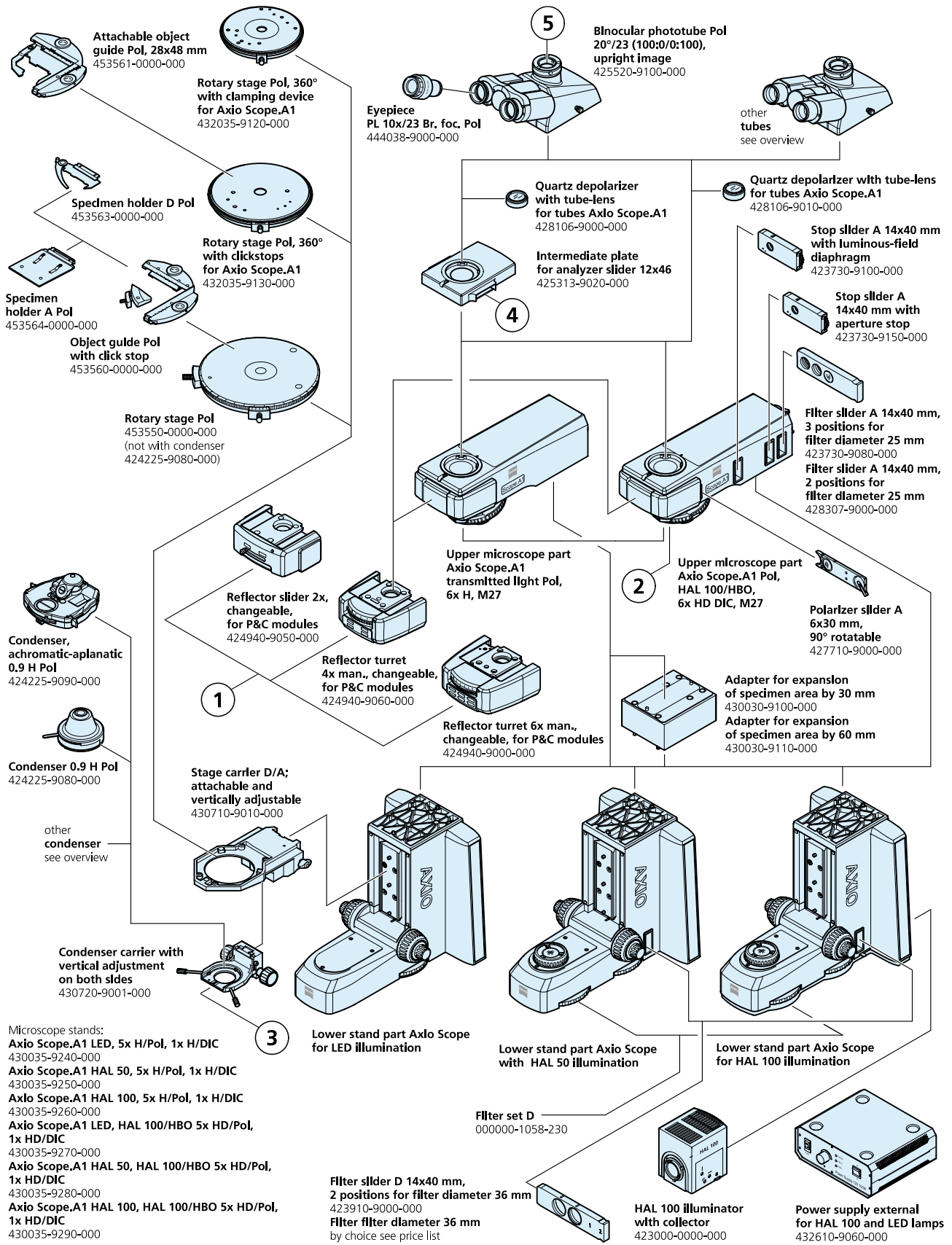

Accessories for polarization

1



Reflector module brightfield ACR P&C for reflected light
424928-9901-000

Reflector module darkfield ACR P&C for reflected light
424922-9901-000

Reflector module Polarizer ACR P&C for reflected light
424923-9901-000

Reflector module Pol ACR P&C for HBO 100 for reflected light
424924-9901-000

Reflector module DIC/Pol red I ACR P&C for reflected light
424938-0000-000

Reflector module DIC/Pol ACR P&C for reflected light
424939-0000-000

Reflector module with analyzer ACR P&C for reflected light
424941-9050-000

Analyzer module Pol ACR P&C for transmitted light
424937-9901-000

2

Analyzer slider D, fixed
433605-0000-000

Compensator lambda, 6x20
473704-0000-000

Compensator lambda/4, 6x20
473714-0000-000

Wedge compensator 0-4 Lambda, 6x20
000000-1140-633

Compensator lambda, rotary +/-8°, 6x20
473710-0000-000

Tilting compensator K 0-30 Lambda, 6x20
000000-1115-698

Tilting compensator B 0-5 Lambda, 6x20
000000-1115-700

**Rotary compensator
Brace-Köhler Lambda/10, 6x20**
000000-1115-703

3

Polarizer D, fixed removable
427701-0000-000

Polarizer D, 90° rotatable, removable
427706-0000-000

Polarizer rotatable with color filter carrier
427707-0000-000

Polarizer fixed with lambda plate rotatable
445226-0000-000

Circular polarizing equipment D ACR, with rotatable lambda/4 plate for transmitted light
427703-9901-000
including
reflector module lambda/4, ACR P&C

Circular polarizing equipment D fixed with rotatable lambda/4 plate
453623-0000-000
including
slider 6x20 with lambda/4 plate

Color filter carrier 3x for filter d=32 mm
428305-0000-000

LED Illuminator for transmitted light
423904-9902-000

Slider with polarizer for LED illumination
427708-0000-000

4

Quartz depolarizer d=32 mm
453653-0000-000

Analyzer slider D/A, fixed
428101-0000-000

Analyzer slider D/A with lambda-plate, 360° rotatable
428102-0000-000

Analyzer slider D/A, 360° rotatable
428103-0000-000

Analyzer slider D/A with lambda-plate, each rotatable +/- 10°
453663-9901-000

Bertrand lens slider Ph
453671-0000-000

Depolarization slider D/A
428105-0000-000

Note:
Usable only if no camera path deflecting system on the left side is inserted:

5

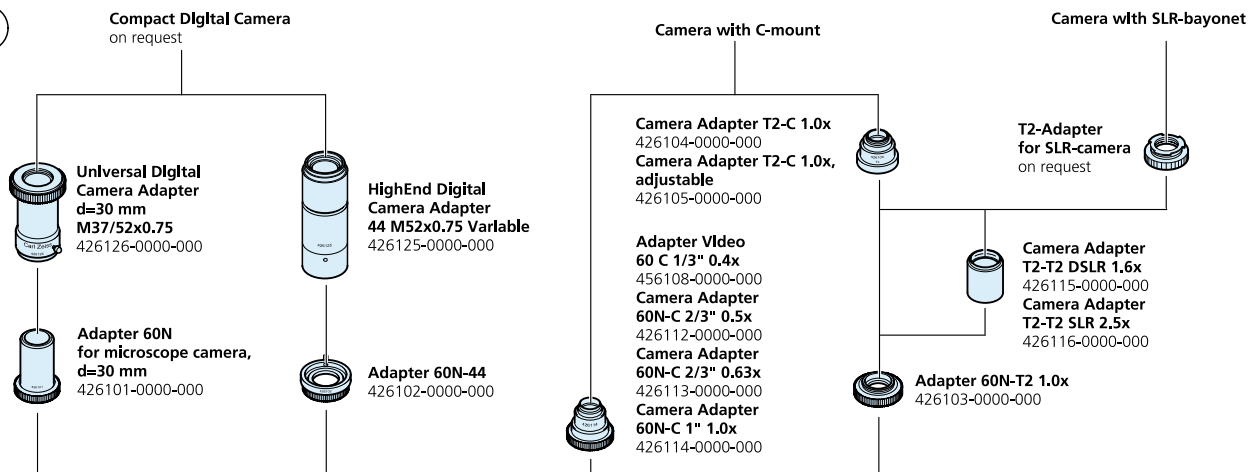

Axio Imager 2 for polarization

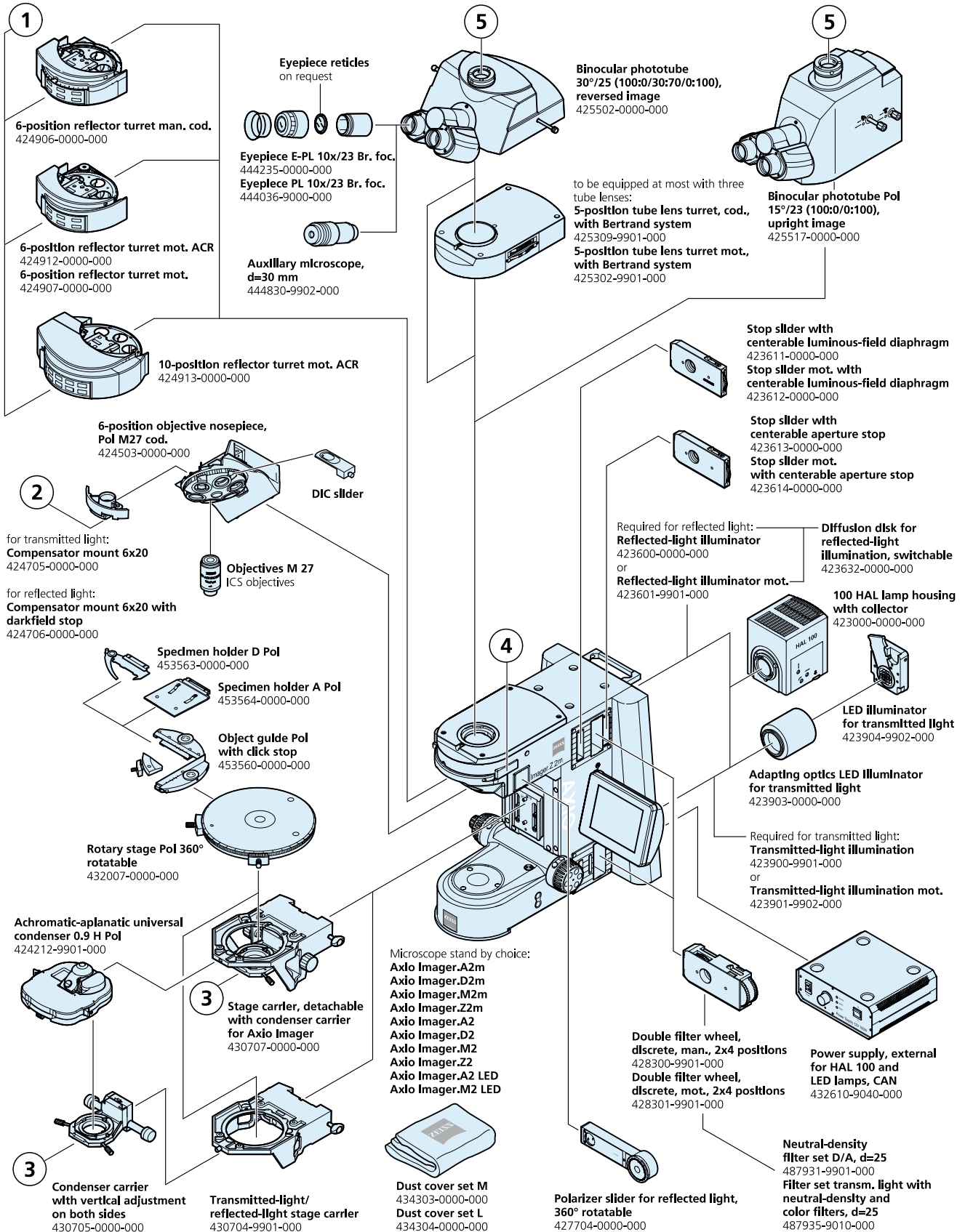



Today as ever, Carl Zeiss sets standards in polarization microscopy, providing a wide range of innovative system solutions designed to fulfill each of your requirements. Our solutions provide economy for education purposes, versatility for a wide variety of routine measurement tasks and powerful efficiency and functionality for science and research.

Two microscope stands form the basis for our system solutions: Axio Scope and Axio Imager – the former a robust multi-purpose routine stand, the latter a leading-edge microscope for research and science. Both equally signify our promise of quality in the field of polarization microscopy – from traditional areas such as mineralogy and geology to current advances in material applications, such as thin layer systems or solar cells. More than just the sum of its parts, a polarization microscope from Carl Zeiss constitutes a meticulously designed complete system solution, perfectly integrated in the Carl Zeiss system environment.

Carl Zeiss Microscopy GmbH

07745 Jena, Germany

Materials

microscopy@zeiss.com

www.zeiss.de/polarization